

REVEL LOUNGE

Aquaglide

Liquid Lounge Series

Item Number: 585221114
SKU: 0790628045056
Dimensions: L 10' x W 10' x H 7.44'
 (L 3,05m x W 3,05m x H 2,27m)

Box Dimensions:
 L 170cm x W 75cm x H 45cm, 90kg

Featuring laid-back tatami-style seating around a family-size table, the Revel Lounge includes inflatable backrests and mesh-bottom footwell and cooler cutouts. The entire layout sits beneath a canopy top cover for added shade. The Revel Lounge accommodates six users and can be used as a standalone accessory or as a social space in any Aquaglide park layout.

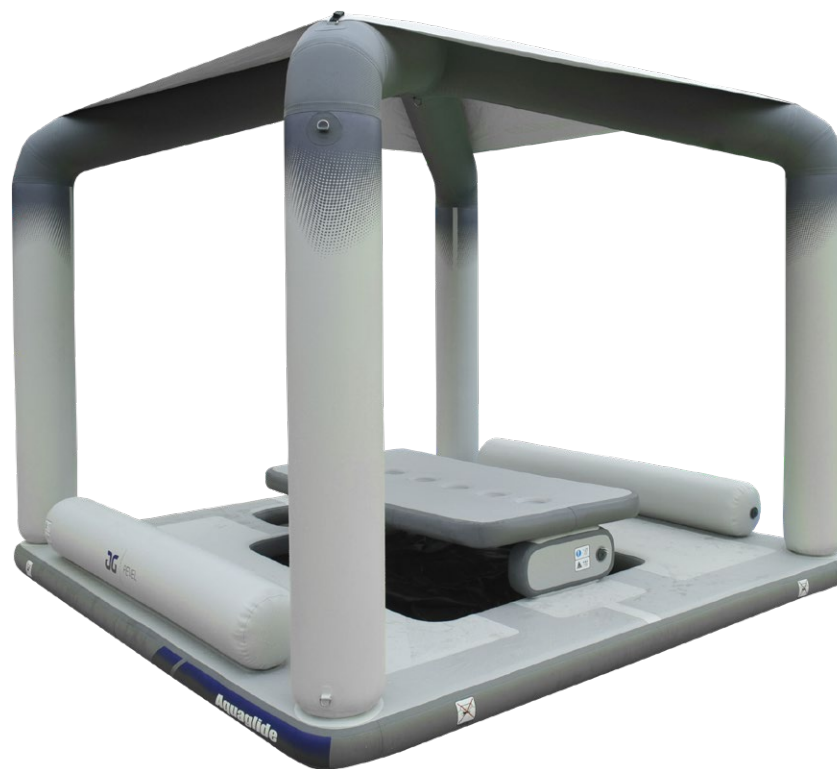

Includes:

- Revel Lounge
- Repair kit

Not Included:

- Anchor weights
- Mooring lines
- Vario Lock™ straps
- Inflation pump

Recommended Items:

- Accelerator HP 12v 20 Pump
- Aquapark 110v 7.3 Pump
- Complete Mooring Line, 19 ft (5,79m)

Best For:

Socializing and lounging

Warranty:

Limited 3-year Lakefront / 1-year light Commercial

Material:

Welded DS 15cm + 0.90mm Cx3

Construction:

Welded structural tube construction with 3-layer seams

Mooring Diagram

* We recommend using Aquaglide mooring lines and weight recommendations as a starting point. Weighted anchors can be either poured concrete or Aquaglide's Lakefront Anchoring System.

It is the responsibility of the owner/ operator to consider the needs of their specific site, to monitor anchored items, and to make adjustments as necessary. Some circumstances may require additional weight or different types of mooring.

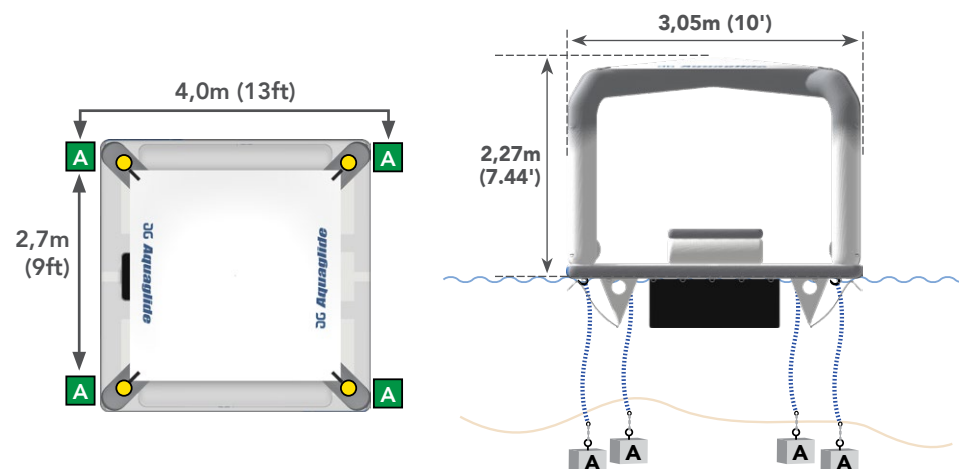

USERS
ADULT / CHILD

6 | 6

MAX WEIGHT
CAPACITY KG | LBS.

544 kg
(1200 lbs.)

MINIMUM
WATER DEPTH

0,98m
(3.3ft)

MIN. DISTANCE AWAY
M | FT

3,0m
(10ft)

MIN. TOTAL
ANCHOR WEIGHT

400 kg
(1000 lbs.)

MIN. WEIGHT
PER ANCHOR

100 kg
(250 lbs.)

NUMBER OF
ANCHOR WEIGHTS

4

ANCHOR
RINGS

4

VERTICAL
MOORING LINES

4

D-RINGS

7 | 0 | 7 | 0

WORKING PRESSURE

Main [1] 6.0psi
(0,414bar), Upper [2]
4.0psi (0,276bar), Base
[3] 1.2psi (0,083bar),
Table [4] 5.0psi
(0,345bar), Seats [5]
2.0psi (0,138bar)